

LARGE ALUMINUM ELECTROLYTIC CAPACITORS

HB High Temperature Range, For 125°C Use Series

- Wide operating temperature range of -40 ~ +125°C
- With a guaranteed useful life of 10 years at 60°C
- Ideal for industrial applications requiring continuous operation

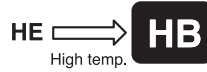

Item	Characteristics							
Operating temperature range	-40 ~ +125°C							
Capacitance tolerance	±20% at 120Hz, 20°C							
Leakage current max.	$I=3\sqrt{CV}$ (µA) (after 5 minutes)							
Dissipation factor max. (at 120Hz, 20°C)	WV	10	16	25	35	50, 63	80~160	200, 250
	tanδ	0.50	0.40	0.30	0.25	0.20	0.17	0.15
Load life (after application of the rated voltage for 1000 hours at 125°C)	Leakage current			Less than specified value				
	Capacitance change			Within ±15% of initial value				
	tanδ			Less than 150% of specified value				
Shelf life (at 125°C)	After 1000 hours no load test, leakage current, capacitance and tanδ are same as load life value.							

● DRAWING

Unit : mm

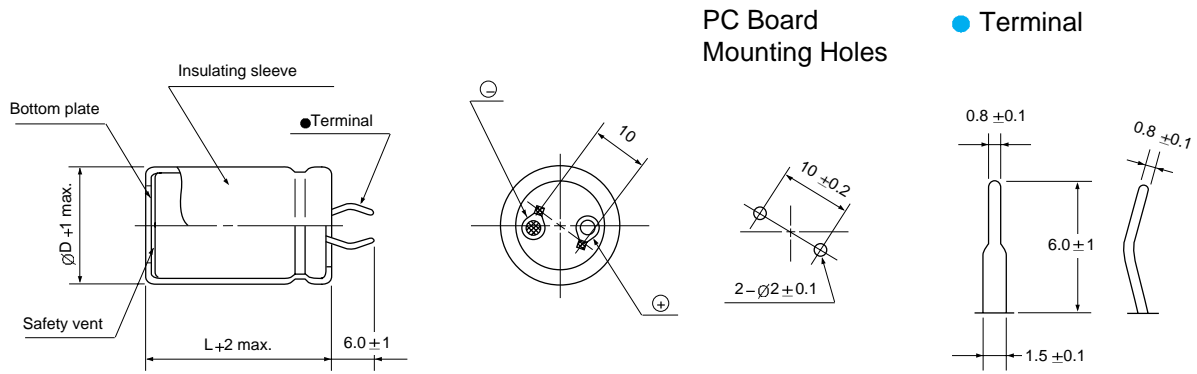

PC Board Mounting Holes

● Terminal

LARGE ALUMINUM ELECTROLYTIC CAPACITORS



HB series

● DIMENSIONS & MAXIMUM PERMISSIBLE RIPPLE CURRENT

WV F ∅D	10				16				25				
	22	25.4	30	35	22	25.4	30	35	22	25.4	30	35	
1500										22×30 0.95			
2200					22×30 1.00					22×40 1.28	25.4×30 1.26		
3300	22×30 1.09				22×40 1.36	25.4×35 1.41				22×50 1.72	25.4×40 1.72	30×30 1.68	
4700	22×40 1.45	25.4×35 1.51			22×50 1.78	25.4×40 1.77	30×30 1.74				25.4×50 2.23	30×40 2.22	35×30 2.17
6800	22×50 1.91	25.4×40 1.91	30×35 1.97				30×40 2.31	35×30 2.26				30×50 2.90	35×40 2.87
10000			30×45 2.62	35×35 2.57				35×45 3.14					
15000				35×45 3.44									

WV F ∅D	35				50				63				
	22	25.4	30	35	22	25.4	30	35	22	25.4	30	35	
470										22×35 0.69	25.4×30 0.71		
680					22×30 0.78					22×40 0.87	25.4×35 0.91	30×30 0.93	
1000	22×30 0.85				22×40 1.06	25.4×30 1.04					25.4×45 1.21	30×35 1.19	35×30 1.22
1500	22×40 1.16	25.4×30 1.14			22×50 1.42	25.4×40 1.42	30×30 1.39					30×45 1.60	35×40 1.65
2200	22×50 1.54	25.4×40 1.54	30×30 1.50				30×40 1.86	35×35 1.91					35×50 2.16
3300			30×40 2.04	35×35 2.09				35×40 2.45					
4700				35×40 2.61									

WV F ∅D	80				100				160				
	22	25.4	30	35	22	25.4	30	35	22	25.4	30	35	
150										22×30 0.37			
220					22×30 0.48					22×40 0.50	25.4×30 0.49		
330	22×30 0.59				22×40 0.66	25.4×30 0.65				22×50 0.67	25.4×40 0.67	30×30 0.65	
470	22×40 0.79	25.4×35 0.82			22×50 0.86	25.4×40 0.86	30×35 0.89				25.4×50 0.87	30×40 0.86	35×30 0.84
680		25.4×40 1.04	30×35 1.07				30×40 1.12	35×30 1.09				30×50 1.12	35×40 1.11
1000			30×45 1.42	35×35 1.40				35×40 1.46					35×50 1.46
1500				35×45 1.86									

WV F ∅D	200				250			
	22	25.4	30	35	22	25.4	30	35
100					22×30 0.32			
150	22×35 0.42				22×40 0.44	25.4×30 0.43		
220	22×45 0.56	25.4×40 0.58	30×30 0.57		22×50 0.58	25.4×40 0.58	30×35 0.60	35×30 0.61
330		25.4×50 0.77	30×40 0.77	35×30 0.75			30×45 0.80	35×35 0.79
470			30×50 0.99	35×40 0.98				35×45 1.03
680				35×50 1.28				

← Case size ∅D × L (mm)
← Ripple current (A rms) at 125°C, 120Hz